

# PARAMAGNETIC OXYGEN ANALYZER

DATA SHEET

ZAJ-6

This product is an analyzer which measures oxygen concentration in a sample gas by converting it into pressure, utilizing the magnetic property of oxygen.

When compared with the oxygen analyzers of other measuring systems, this oxygen analyzer features a faster response, and smaller influence by coexisting gas and combustible gas, etc.

Further, this analyzer is easy to use because of abundant functions such as discretionary range setting and interactive operation. It is usable in diverse field including control of various heat treating furnaces, combustion furnaces and other various fields.



## FEATURES

- 1. Non-contact detector with long-term superior stability**  
 The auxiliary gas is constantly drawn into the detector to prevent the detector from contacting with sample gas. This keeps the analyzer from contamination or corrosive gas, and thus ensuring its long-term stability.
- 2. Highly sensitive mass flow sensor enables low concentration measurement**  
 The highly sensitive mass flow sensor is capable of O<sub>2</sub> measurement with minimum range of 0 to 1 vol%.
- 3. Fast response: 90% response within 2 seconds**  
 The thin measuring cell in which sample gas flows so quickly enables fast measurement of O<sub>2</sub> concentration.
- 4. Long-life detector with no moving parts**  
 Free from maintenance work because the detector has no moving parts. It also features vibration-proof and impact-resistant structure thanks to optimized flow channel. The sample cell is made of SUS304 which has high corrosion resistance.
- 5. Interference compensation function (optional)**  
 Interference from other gas which has magnetic characteristics can be corrected. Interference compensation is performed by measuring concentration of coexisting gas and inputting it as 1-5V DC signal.

## SPECIFICATIONS

### Measuring range:

Measuring range: Freely settable

Measuring range (vol% O <sub>2</sub> )	Reference gas
0 ~ 0.5 ... 100	N <sub>2</sub> (100% vol% N <sub>2</sub> )
21 ~ 23 ... 100	Air (21 vol% O <sub>2</sub> )
100 ~ 98 ... 0	O <sub>2</sub> (100 vol% O <sub>2</sub> )

**Numbers of range:** 2 ranges

**Measuring system:** Paramagnetic pressure type

**Output signal:** 4 to 20mA DC (load 550Ω max.)

**Repeatability:** Within ± 1% of full scale

**Zero drift:** Within ± 1.5% of full scale/week

**Span drift:** Within ± 1.5% of full scale/week

**Flow rate of sample gas:**

0.5L/min ± 0.05L/min (in ranges below 2 vol% O<sub>2</sub>)

0.5L/min ± 0.2L/min (in 2 vol% O<sub>2</sub> or higher ranges)

**Response time (90% response: \*Indication start-up time):**  
2s or less

\*The time (= 1sec.) required for gas replacement in the internal piping is not included.

**Linearity:** Within ± 1% of full scale

**Reading fluctuation:**

≤ ±2.0% FS for 0–2% or lower ranges

≤ ±1.5% FS for ranges above 0–2%

**Sample gas temperature:** 0 to 40°C

**Pressure loss:**

Approx. 1.3kPa (at sample gas flow rate 0.5L/min)

**Reference gas:** N<sub>2</sub>, O<sub>2</sub> gas or air

**Reference gas pressure:** 100kPa

\*Reference gas is supplied at the above pressure to allow for flow rates of 5 to 20mL/min.

**Purging gas (dry air or N<sub>2</sub>) flow rate:** 1L/min, N<sub>2</sub> gas or air (flowed for purging corrosive ambient gas)

**Gas inlet/outlet dimensions:** Rc1/4 or NPT1/4

**Materials of gas-contacting parts:**

Teflon and 304 stainless steel

**Warmup time:** Approx. 2 hours

**Display:**

Liquid crystal display, concentration indication (4 digits), range indication (4 digits)

**Output hold:**

Output hold is possible during calibration.

**Moving average time:** 0 to 99.9s

**Contact output:**

SPST-NO contact, contact capacity: 250 V AC, 2A (resistive load)

Contact is closed during calibration and instrument failure

**Power supply:** 85 to 264V AC, 50/60Hz

**Power consumption:** Approx. 90VA

**Ambient temperature:** -5 to +45°C

**Ambient humidity:** Less than 90% RH

**Allowable (max.) external vibration:**1.0m/s<sup>2</sup>{0.1G}(0 to 30Hz)0.5m/s<sup>2</sup>{0.05G}(30 to 100Hz)**Enclosure:** Steel, for indoor use**External dimension (H×W×D):**

Rack mount type 133 × 483 × 433mm

Flush mount type 132 × 483 × 433mm

Desk-top type 148 × 429 × 433mm

**Mass:** Approx. 9.5kg**Finish color:** Front panel: Cool gray

Casing : steel

**Installation condition:**

- The instrument must be protected from direct sunlight and heat radiation from objects at high temperature.
- The instrument must be installed in a clean atmosphere free from corrosive or combustible gas.
- The instrument must be free from severe external vibrations. When fast response time is required, it should be used in a place free from vibration.

**Mounting method:**

Mounting on 19-inch rack, flush mounting on panel or desk top mounting

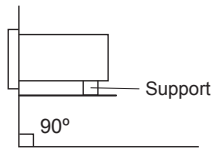

Note: At least 70% of the weight of the instrument must be supported by the bottom of the case. When mounting the instrument on a panel or 19-inch rack, add a support under rear side of the instrument.

**EU Directive Compliance** **LVD (2014/35/EU)**

EN 61010-1

EN 62311

**EMC (2014/30/EU)**

EN 61326-1 (Table 2)

EN 55011 (Group 1 Class A)

EN 61000-3-2 (Class A)

EN 61000-3-3

EN 61326-2-3

**RoHS (2011/65/EU)**

EN 50581

**OPTIONAL SPECIFICATION****Alarm output:**

Upper limit alarm: SPDT contact

Contact capacity; 250 AC, 2A  
(resistive load)

Lower limit alarm: SPDT contact

Contact capacity; 250 AC, 2A  
(resistive load)**Remote range changeover:**

Range can be changed by external signal

Signal input for range changeover; 5V DC

**Range identification signal output:**

Contact output; SPST-NO contact

Contact capacity; 250 AC, 2A (resistive load)

**Output hold:**

Each output can be held by external input signal of 5V DC

**Communicating function:**

RS-485 (MODBUS)

Half-duplex bit serial, start-stop synchronization

Contents: Parameter settings (read/write), measured values (read), instrument status (write)

Remark : When connecting via RS-232C interface, an RS-232C ↔ RS-485 converter should be used.

**Automatic calibration:**

Zero/span calibration is performed automatically at a preset cycle.

Calibration gas is supplied while driving the external electromagnetic valve.

Calibration gas density setting range:

Zero gas: 0.00 to 99.99%O<sub>2</sub> (0.01%O<sub>2</sub> step)Span gas: 0.00 to 99.99%O<sub>2</sub> (0.01%O<sub>2</sub> step)

Calibration start:

Built-in timer or remote start signal

Output hold during calibration: Possible

Calibration gas flow time:

Configurable between 60 to 599 seconds

Calibration cycle:

1 to 99 hours (in hours) or 1 to 40 days (in days)

Contact output:

Calibration: SPST-NO contact

Contact capacity: 250V AC, 2A (resistance load)

Calibration error: SPST contact

Contact capacity: 250V AC, 2A (resistance load)

Contact output for solenoid valve: SPST contact

Contact capacity: 250V AC, 2A (resistance load)

Remote start:

Remote start input signal:

5 V DC pulse signal for 100 ms or longer

**Interference correction by interference gas measured value input:**The analyzer measures the concentration of the interference gas you selected, and calculates O<sub>2</sub> concentration based on the change of the interference gas concentration.

External interference gas measured value input:

1 to 5 V DC, 1range

Interference gas fluctuation range:

Reference concentration ± 20% F.S.

O<sub>2</sub> gas concentration correcting range:

Reference concentration ± 20% F.S.

Correction accuracy: ±10% F.S.

Requires factory adjustment.

Details of measurement gas will be checked when receiving an order.

# CODE SYMBOLS

Digit	Specifications			ZAJ														
4	-			5														
5	Measuring range (Note 1)	Mini. range 5/Max.range 100 vol% O <sub>2</sub> (Without buffer tank) Mini. range 5/Max.range 100 vol% O <sub>2</sub> (With buffer tank) Mini. range 0.5/Max.range 100 vol% O <sub>2</sub> (With buffer tank)		Y	A	B												
6	Response time	2sec/90%		2														
7	Connecton dimension	Rc1/4 NPT1/4		5	7													
8	Revision code	-		6														
9	Gas inlet, outret	Rear Front								1	2							
10	Display	Japanese English Chinese								N	E	C						
11	Option 1	Without Automatic calibration Alarm output, remote reange, range identification Communication function (RS-485) ----- A+B A+C B+C A+B+C												Y	A	B	C	
														D	E	F	G	
12	Construction	<Mounting>	<Power swich>	<Power terminal>														A
		Desk-top type	Front	Terminal block														B
		Desk-top type	Front	AC Inlet														C
		Rack/panel mount	Front	Terminal block														D
		Rack/panel mount	Front	AC inlet														E
		Rack/panel mount	Rear	AC inlet														
13	Option 2	Without Interference gas compensation (Note2)																Y
																		A

Note 1) Factory default measurement range: 0 to 5/25 vol% O<sub>2</sub>.

Note 2) • If you order the product version with the interference compensation function, fill in the table for checking sample gas component attached on the last page.

- An additional analyzer is required for measuring interference gas (CO<sub>2</sub> or CH<sub>4</sub>).
- Input signal is 1 to 5V DC.
- Requires factory adjustment.
- Reverse range such as 100 to 0 %, and atmospheric air standard range are not available.

# PRINCIPLE DIAGRAM

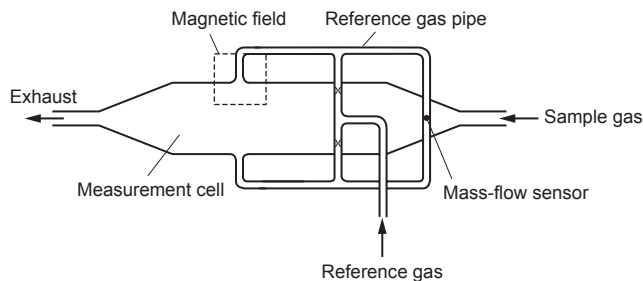

When the measured gas is placed in a magnetic field, oxygen molecules will be attracted. This gives rise to a pressure, which is detected by a mass flow sensor.

## CONSTITUTION

Sampling system diagram (Example)

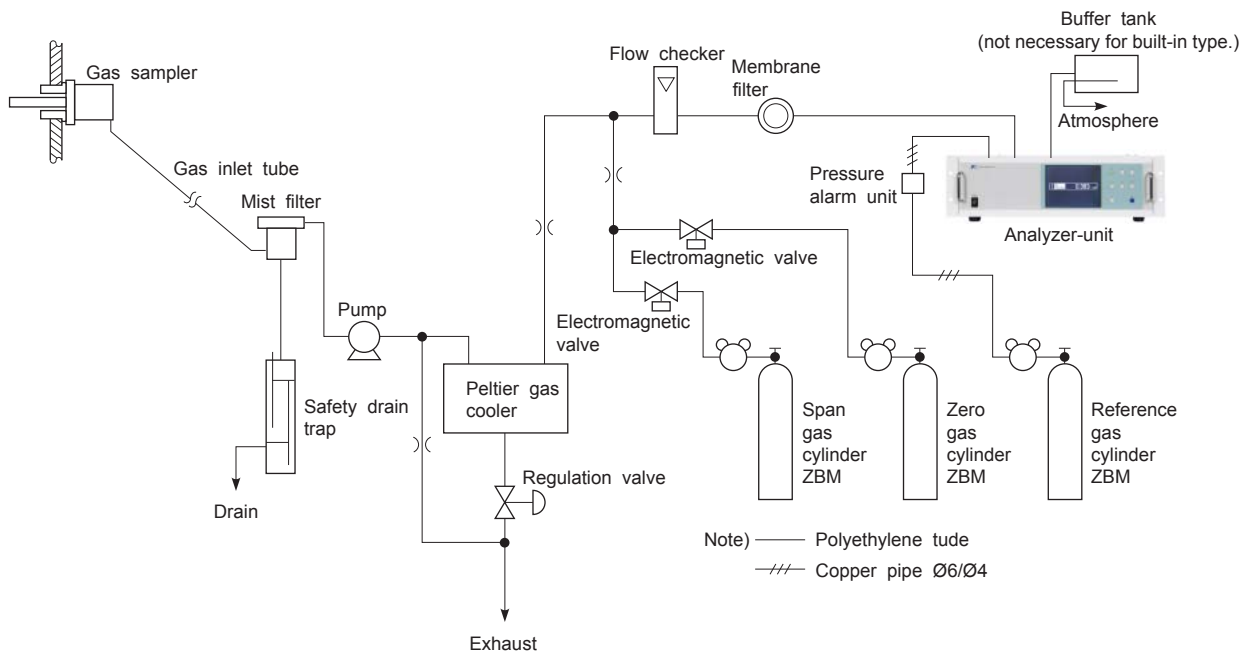

## SCOPE OF DELIVERY

Analyzer × 1  
 Fuse × 2  
 Instruction manual × 1  
 Accessory kit (orifice × 1, packing × 6, filter × 2)

## ITEMS TO BE PREPARED SEPARATELY

- (1) Standard gas for calibration  
 Code symbol ZBM□SY04-01
- (2) Reference gas
  - Measuring range 0 to 1 ... 100 vol% O<sub>2</sub>  
 N<sub>2</sub> : Code symbol ZBM□NY04-01
  - Measuring range 21 to 23 ... 100 vol% O<sub>2</sub>  
 Air : Code symbol ZBM□RY04-01  
 or instrumentation air
  - Measuring range 100 to 98 ... 0 vol% O<sub>2</sub>  
 O<sub>2</sub> : Code symbol ZBM□SY04-01
- (3) Buffer tank ZBH410□3  
 (Unrequired for versions with buffer tank.)
- (4) For version with interference compensation function  
 CH<sub>4</sub> or CO<sub>2</sub> analyzer

## Note

- (1) When using this analyzer, be sure to provide a buffer tank in the exhaust path immediately after the analyzer.  
 This is required for preventing output fluctuation due to disturbances such as large noise and strong wind.  
 (Unrequired for versions with buffer tank.)
- (2) If you use air as the reference gas, order the span gas with the concentration of 80–100% of full scale. Clearly specify that the gas should be made by gravimetric method and have the minimum accuracy corresponding to  $\pm 1\%$  of full scale. Without this description, the span gas may contain unallowable concentration error.  
 Example of 21–23 vol% O<sub>2</sub> range:  
 Span gas concentration: 22.6–23.0% O<sub>2</sub>, balance N<sub>2</sub>  
 Accuracy:  $\leq \pm 0.02\%$  O<sub>2</sub>  
 Made by gravimetric method
- (3) If you use O<sub>2</sub> as the reference gas and the full scale of your measurement range is 10 vol% O<sub>2</sub>, use zero gas that has a minimum purity of 99.99%. For other ranges, use the zero gas that has minimum purity of 99.9%.
- (4) Use a copper pipe (6/4 copper pipe) for the reference line. It should be as short as possible from the gas cylinder. The longer the pipe is, the longer the time is required until the reading stabilize. Do not use a plastic pipe, as it causes errors in reading due to permeation of oxygen.

# OUTLINE DIAGRAM (Unit : mm)

## Rack/panel mount type

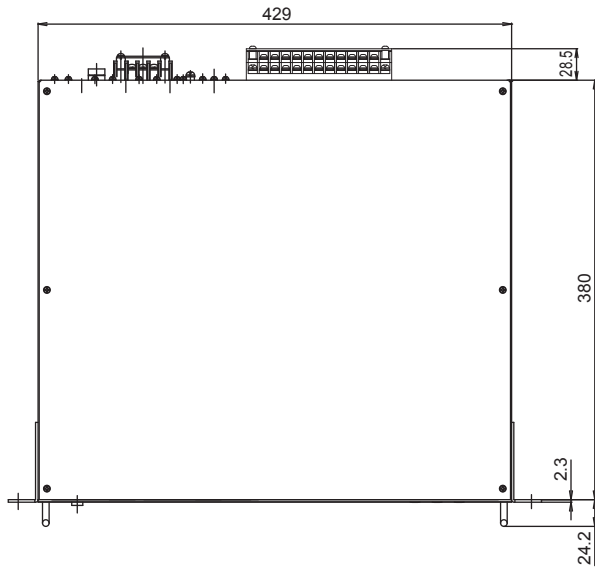

Front view

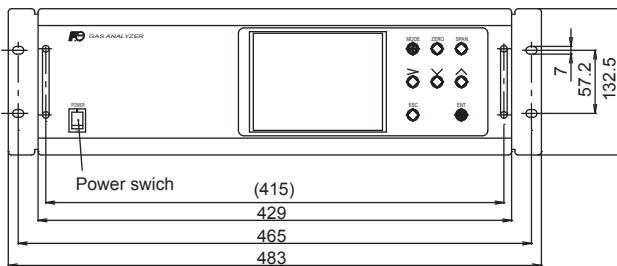
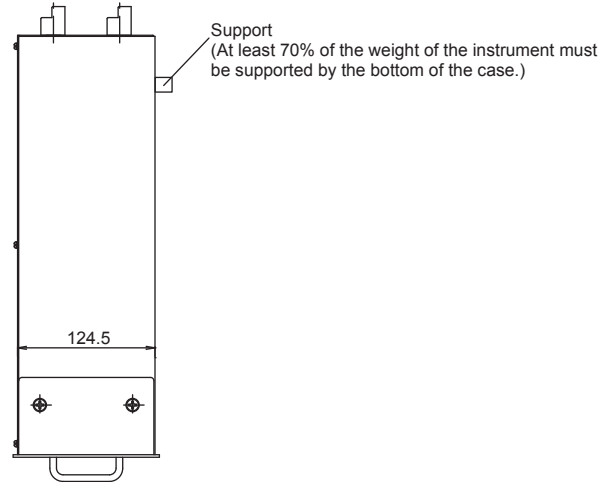

<Gas inlet and outlet : rear>

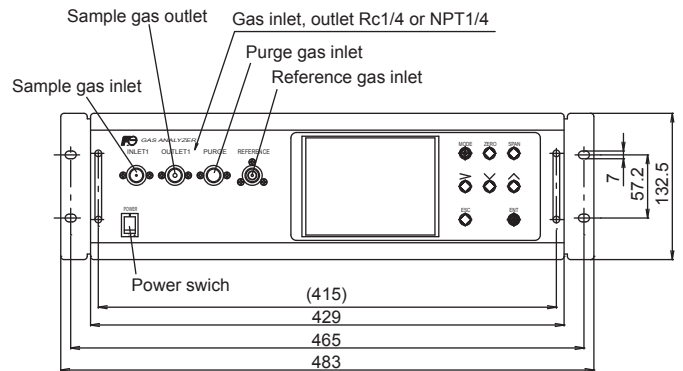

<Gas inlet and outlet : front>

## Rear view

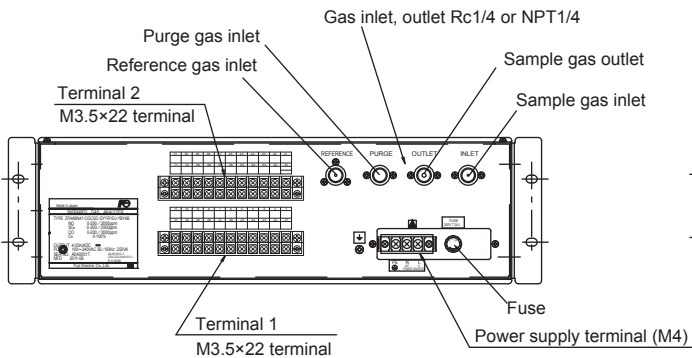

<Gas inlet and outlet : rear>

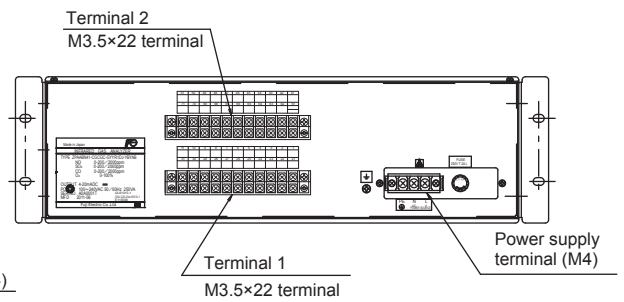

<Gas inlet and outlet : front>

Inlet power source, power switch on front panel

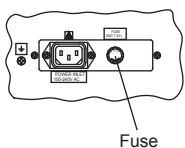

Inlet power source, power switch on rear panel

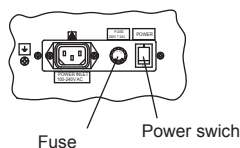

## Panel cutout

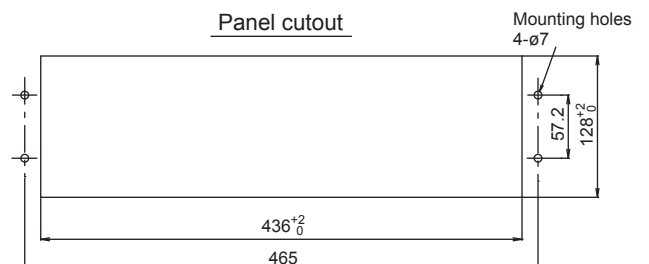

Desk-top type

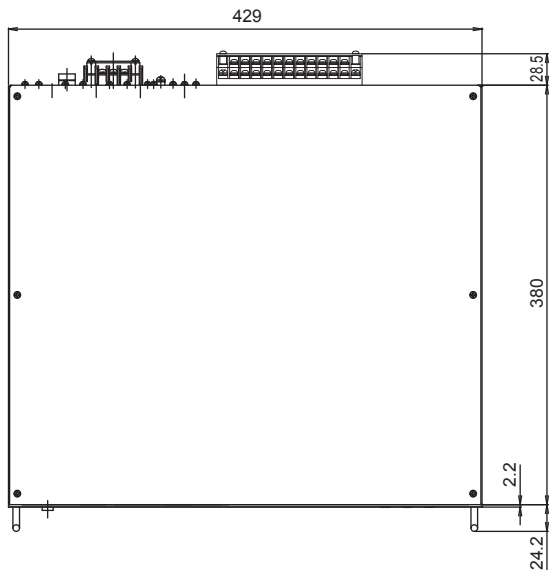

Front view

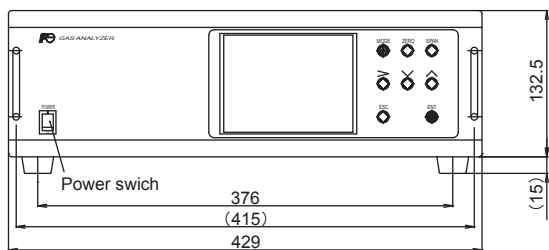

inlet and  
<Gas inlet and outlet : rear>

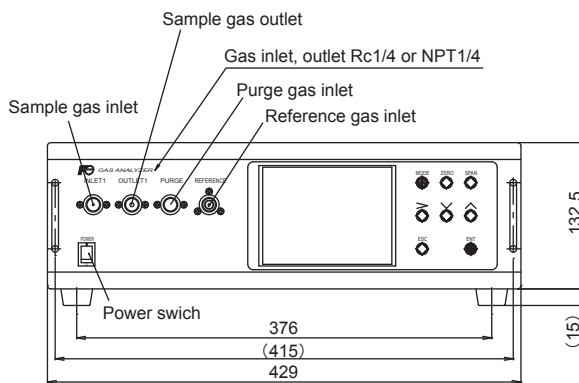

<Gas inlet and outlet : front>

Rear view

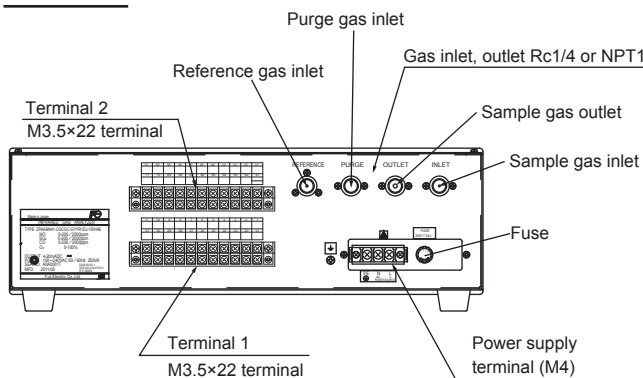

<Gas inlet and outlet : rear>

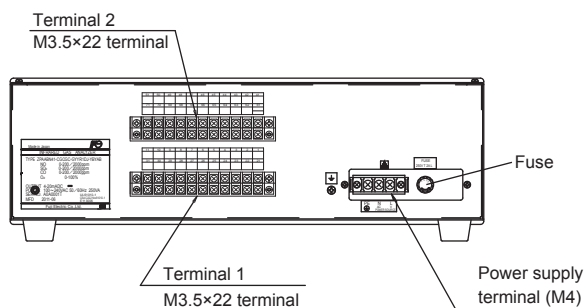

<Gas inlet and outlet : front>

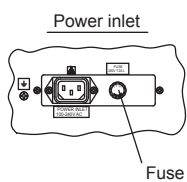

# External connection diagram

## Power supply terminal

### <Terminal type>

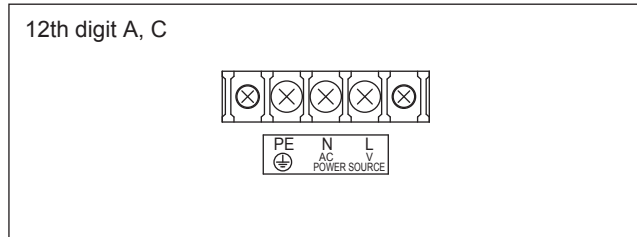

### <Inlet type>

(Power switch on front panel)

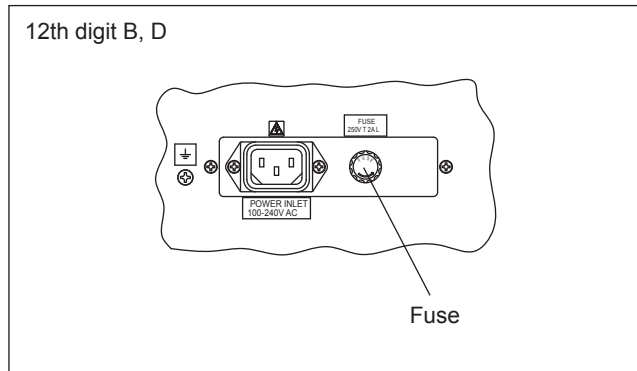

(Power switch on rear panel)

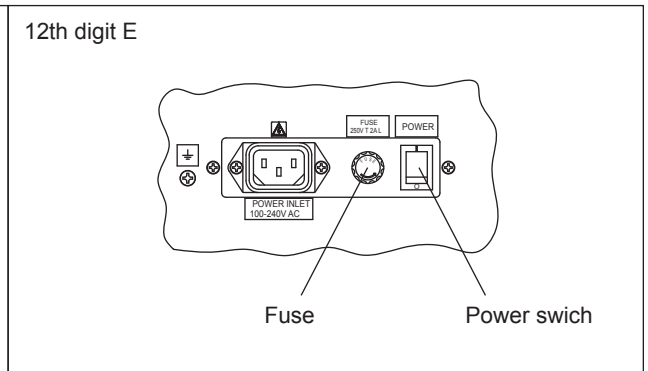

## Input/Output terminal

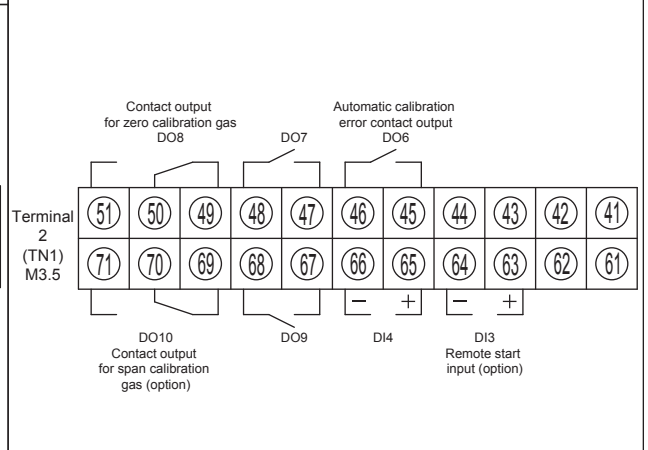
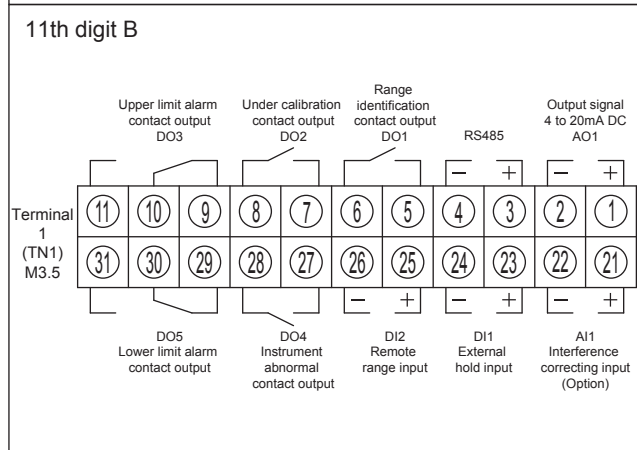
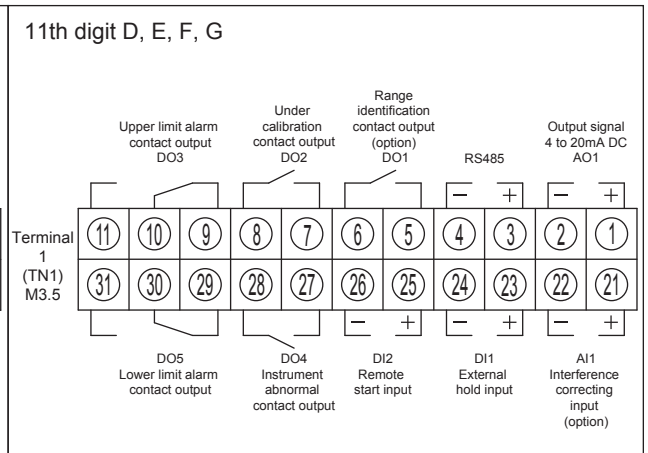
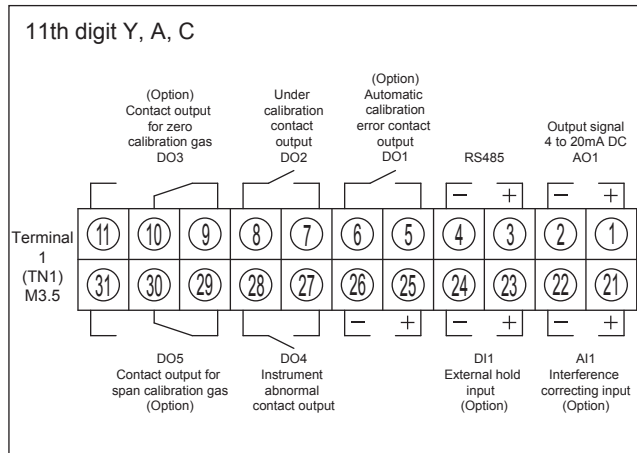

## <Table for checking sample gas component of paramagnetic oxygen gas analyzer (ZAJ-6)>

Let us check your sample gas for safe use of Fuji Electric' gas analyzer.  
 Make entries where you can answer. If there is any question, contact our salesperson in charge of your company.  
 The analyzer may not provide full performance depending on other gas components contained in sample gas.

Date

Item	Description
Name of customer at delivery destination	
Application, purpose	
Gas component to be measured	O <sub>2</sub>

Sample gas		Minimum concentration (%)	Normal concentration (%)	Maximum concentration (%)	Remarks
Component to be measured	O <sub>2</sub>				
Other component gas					
Other component gas					

Interference gas input	Measuring range	Interference gas
	0-	

Your question, etc.	
---------------------	--

Customer information	Company name
	Section
	Address
	TEL
	Person in charge

Fuji Electric's salesperson in charge of your company \_\_\_\_\_

**⚠ Caution on Safety**

\*Before using this product, be sure to read its instruction manual.



**Global Sales Section  
 Instrumentation & Sensors Planning Dept.**  
 1, Fuji-machi, Hino-city, Tokyo 191-8502, Japan  
<http://www.fujielectric.com>  
 Phone: +81-42-514-8930 Fax: +81-42-583-8275  
<http://www.fujielectric.com/products/instruments/>